

10 EXTERIOR WALL - AT FAN COIL  
A 605 1:5

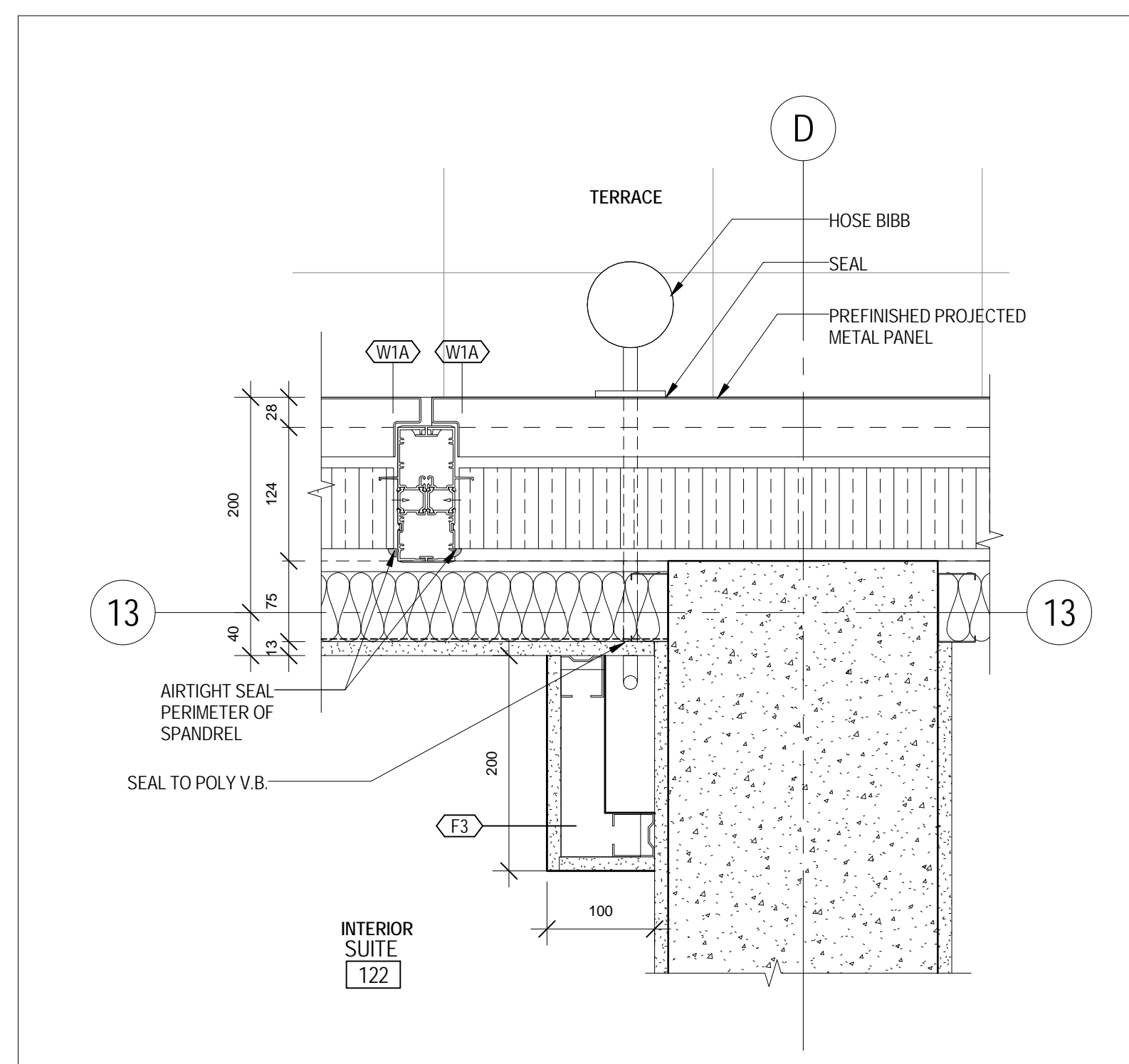

9 HOSE BIBB CONDITION 1  
A 605 1:5

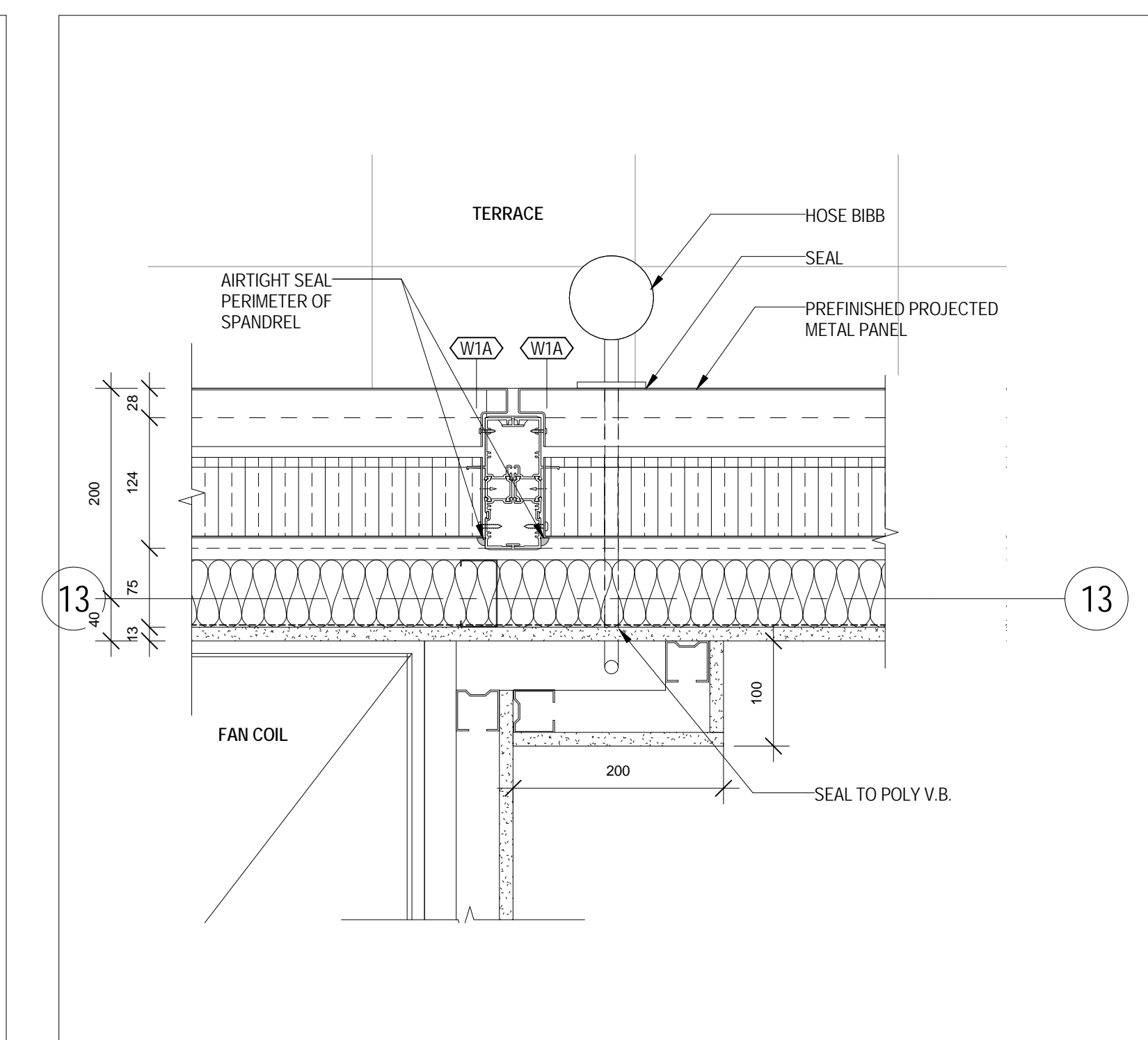

6 HOSE BIBB CONDITION 2  
A 605 1:5

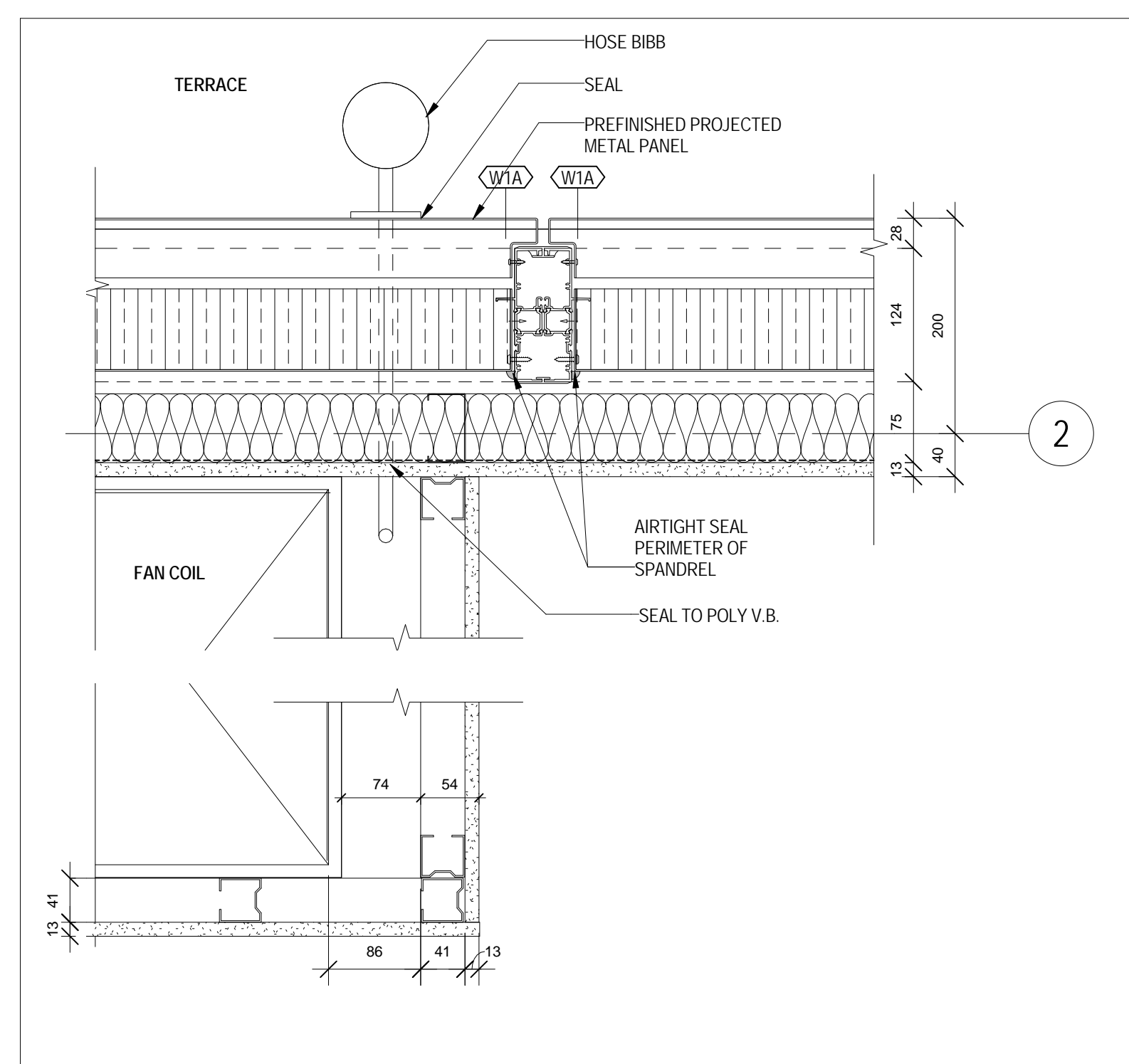

8 HOSE BIBB CONDITION 3  
A 605 1:5

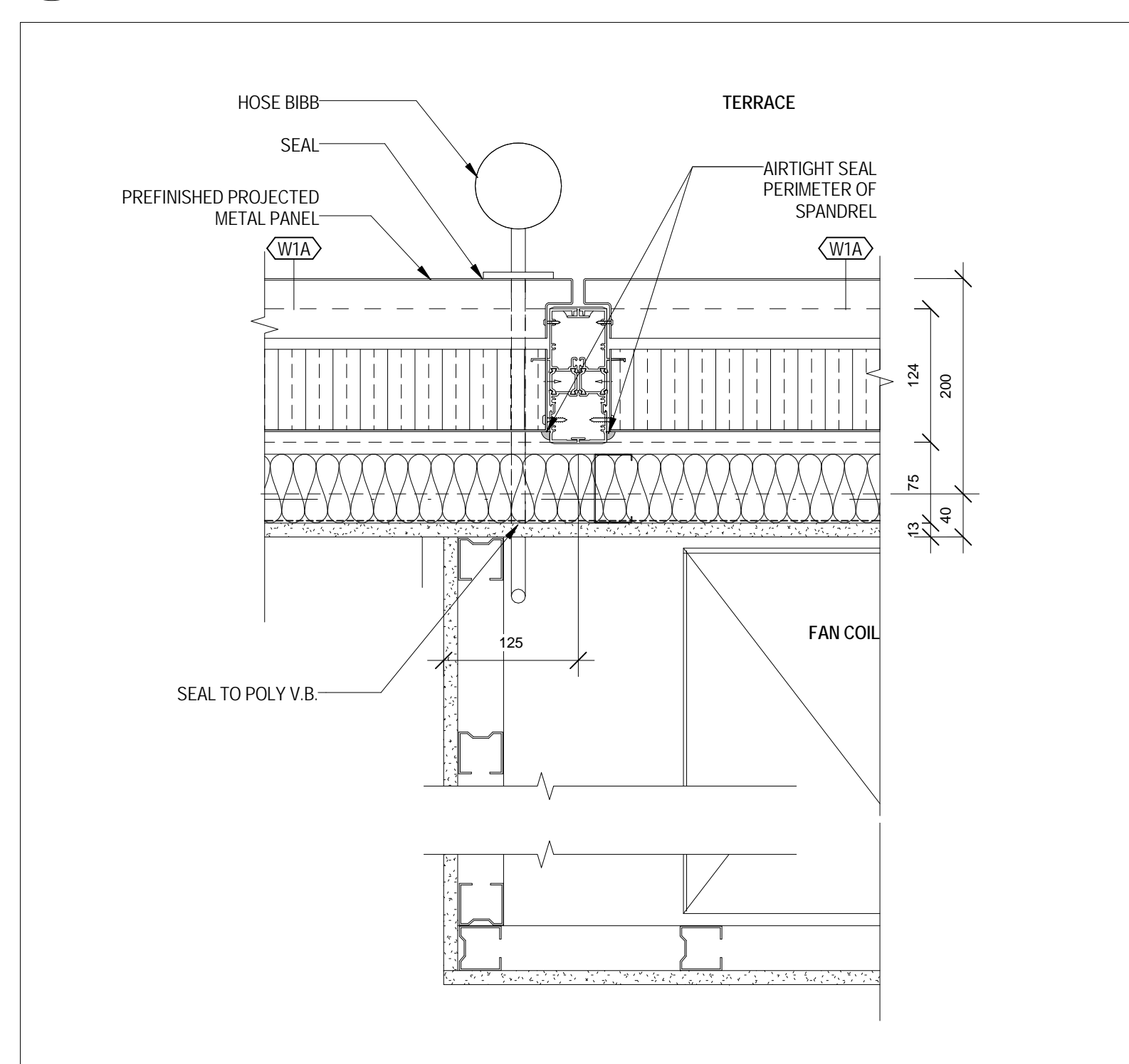

7 HOSE BIBB CONDITION 4  
A 605 1:5

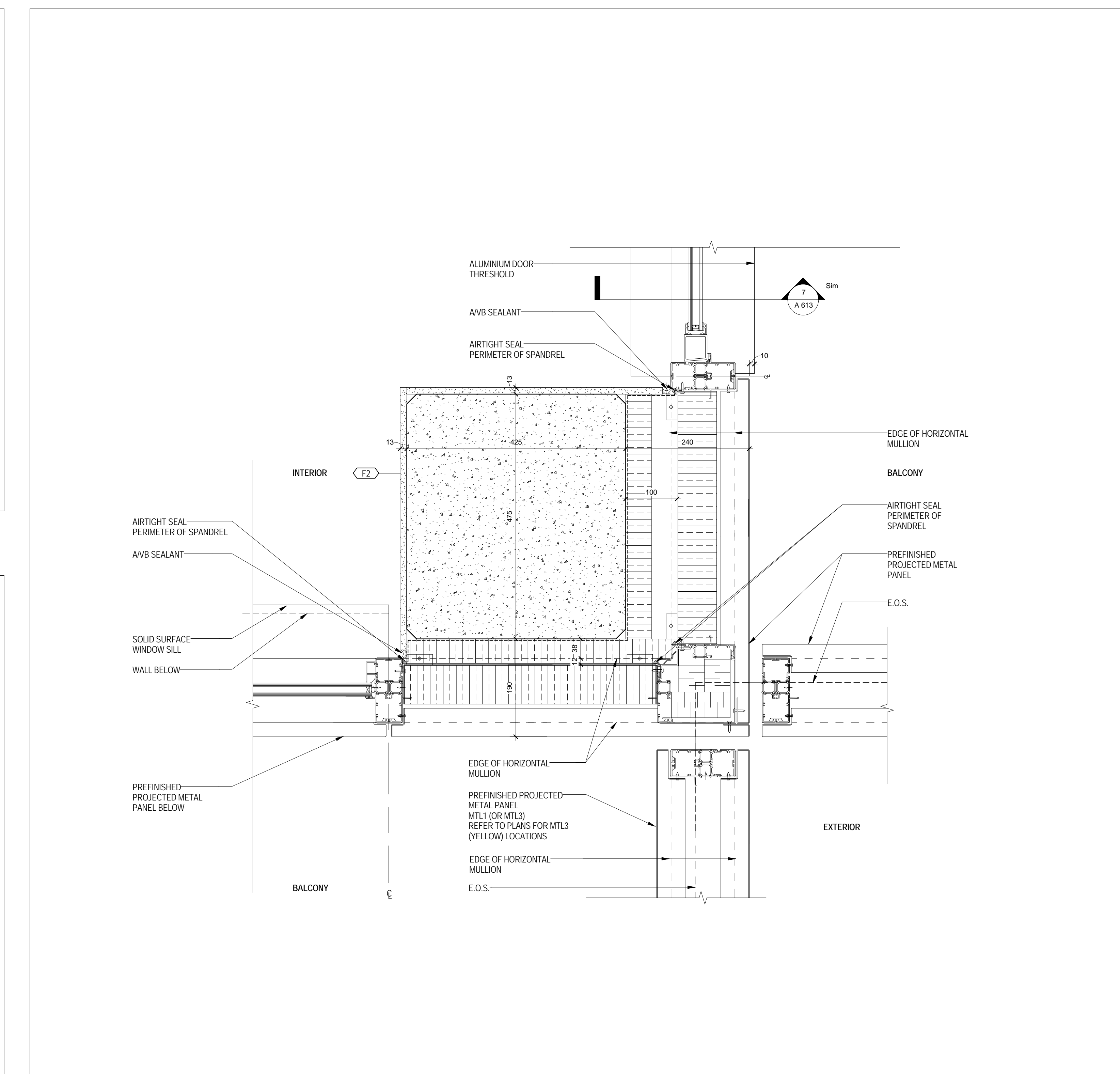

4 EXTERIOR WALL CORNER - AT CORNER COLUMN AND DOUBLE BALCONY  
A 605 1:5

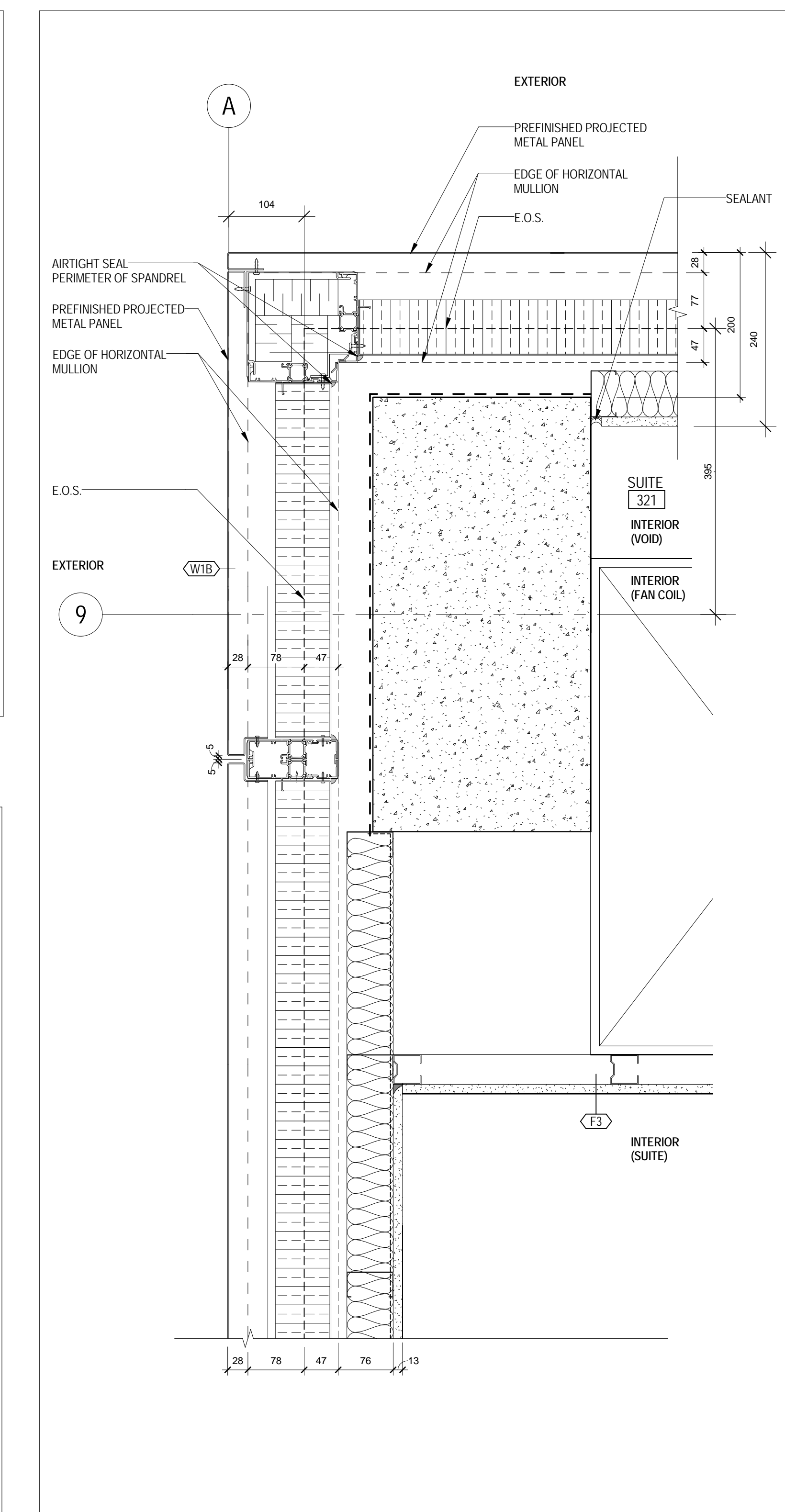

5 EXTERIOR WALL CORNER  
A 605 1:5

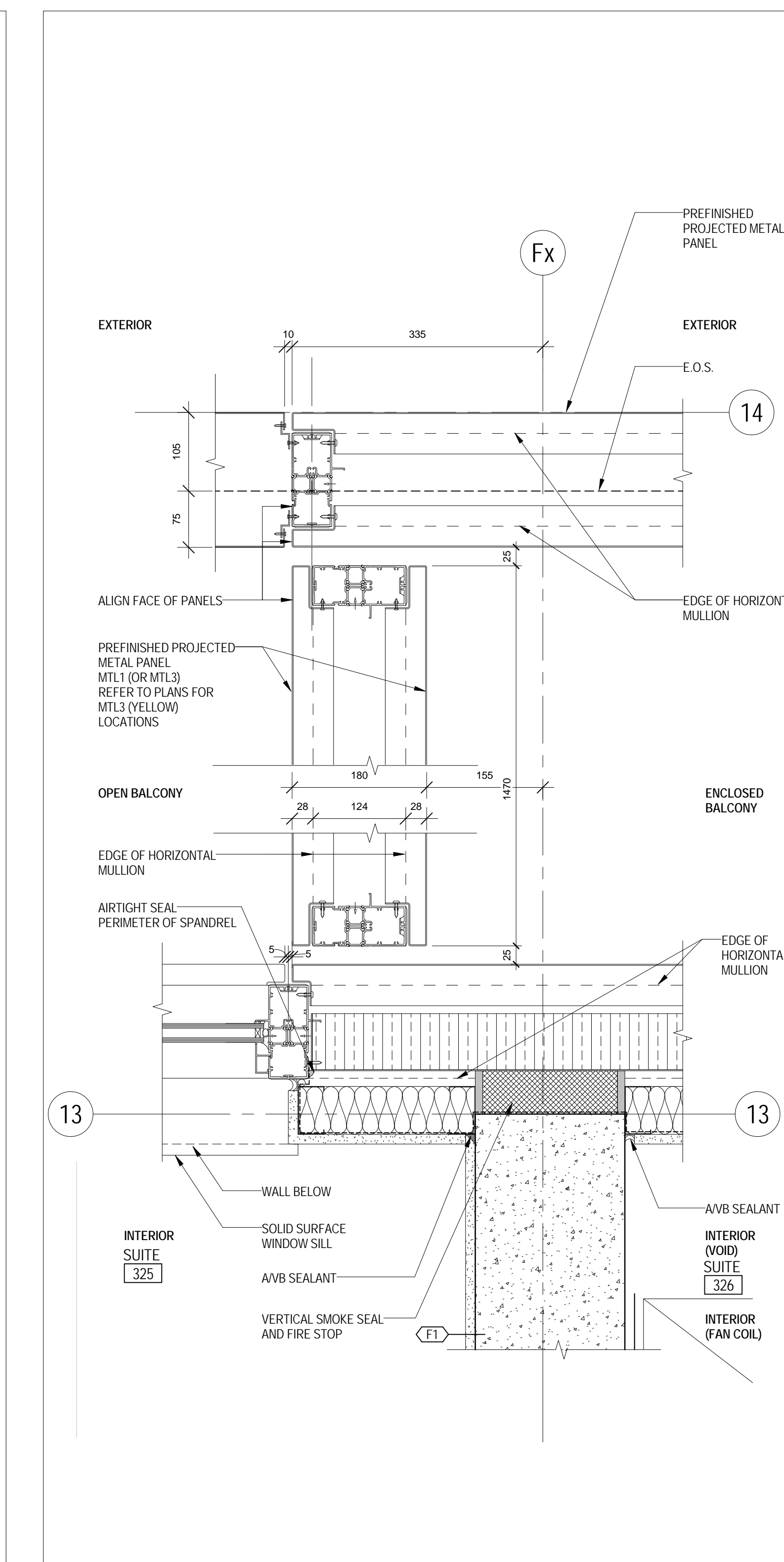

3 ENCLOSED BALCONY TO OPEN BALCONY CONNECTION  
A 605 1:5

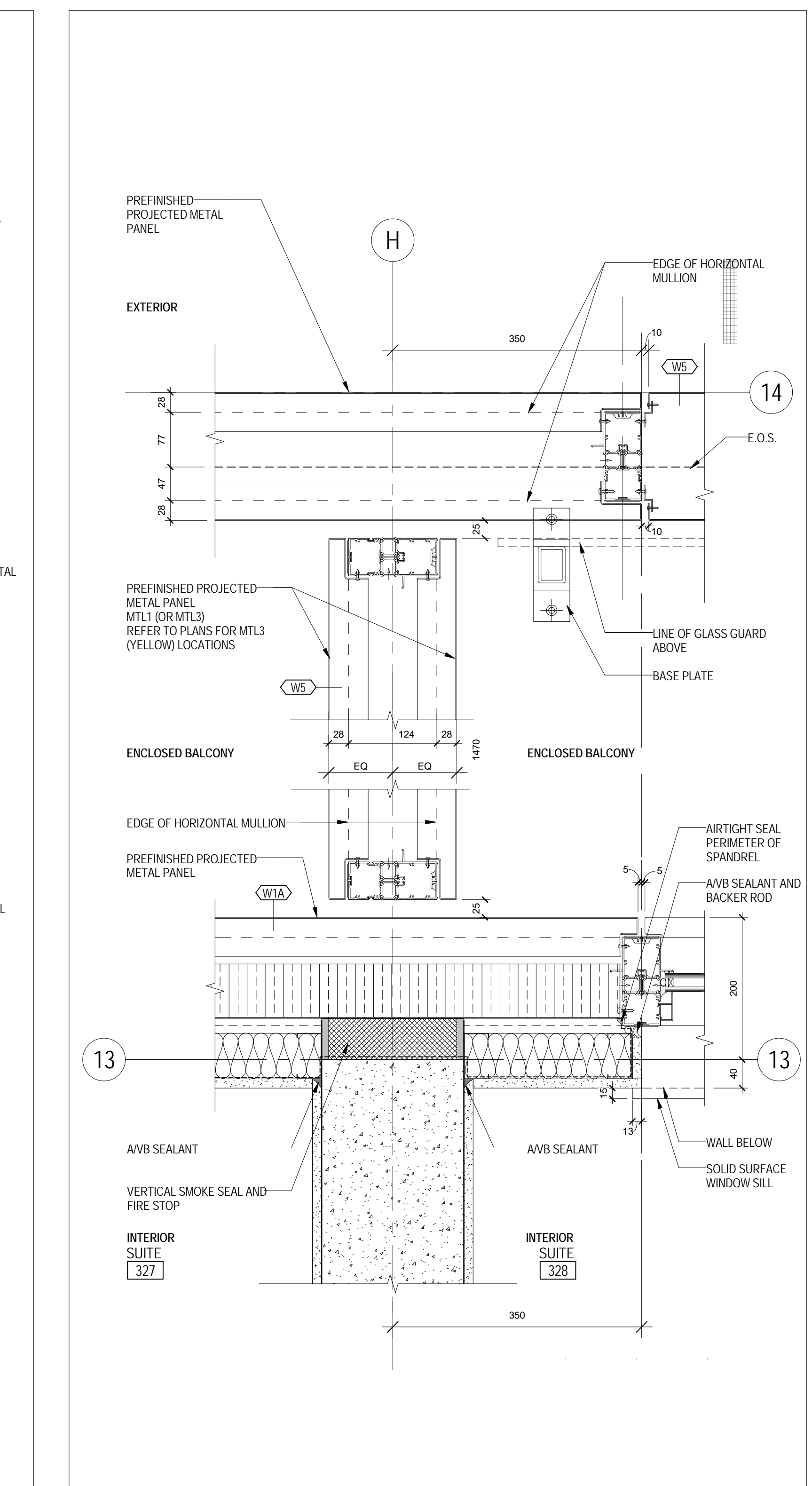

2 ENCLOSED BALCONY TO ENCLOSED BALCONY CONNECTION  
A 605 1:5

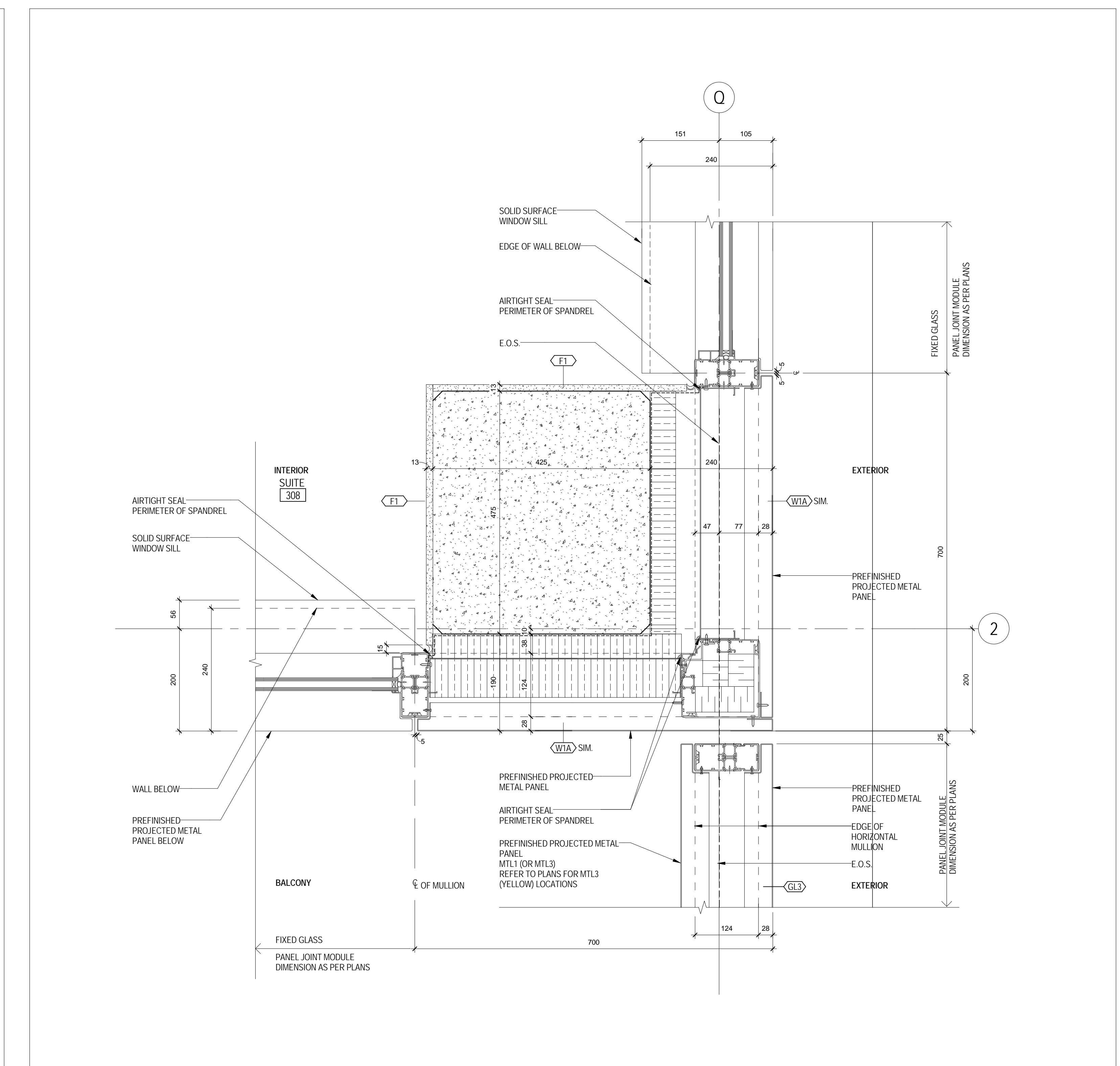

1 EXTERIOR WALL CORNER - AT COLUMN AND BALCONY  
A 605 1:5

THIS DRAWING IS THE PROPERTY OF SQ SPADINA QUEEN TRIDEL. IT IS TO BE USED FOR THE PROJECT AND SITE SPECIFICALLY IDENTIFIED HEREIN. IT IS NOT TO BE REPRODUCED, COPIED, OR TRANSMITTED IN ANY FORM OR BY ANY MEANS, ELECTRONIC OR MECHANICAL, WITHOUT THE WRITTEN PERMISSION OF SQ SPADINA QUEEN TRIDEL. THE DRAWING IS TO BE USED IN CONJUNCTION WITH THE CONTRACT DOCUMENTS AND SPECIFICATIONS. THE CONTRACT DOCUMENTS AND SPECIFICATIONS SHALL PREVAIL IN THE EVENT OF A DISCREPANCY. THE DRAWING IS NOT TO BE USED FOR ANY OTHER PROJECT OR SITE WITHOUT THE WRITTEN PERMISSION OF SQ SPADINA QUEEN TRIDEL.



METRIC SCALE DRAWING  
FIRST FLOOR ELEV. +93.60m

No.	ISSUED/REVISION FOR	DATE
1	Issued for Permit	2014-09-22
2	Issued for Tender	2014-09-22
3	Issued for Tender	2014-09-22
4	Issued for Tender	2014-09-22
5	Issued for Final Tender	2014-09-22

SQ ALEXANDRA PARK - BLOCK 11  
38 CAMERON ST., TORONTO, ONTARIO M5T 2H2

project no: 12-115  
scale: 1:5  
drawn by: Aurur  
reviewed by: Chikael  
date: 2014-09-22

Teepie Architects  
1200 BAYVIEW AVE. SUITE 200  
SCARBOROUGH, ONTARIO M1B 4Y7  
416-291-1111  
PLAN DETAILS - TYPICAL

A 605