

10 EXTERIOR WALL - AT FAN COIL
1/A 206 1:5

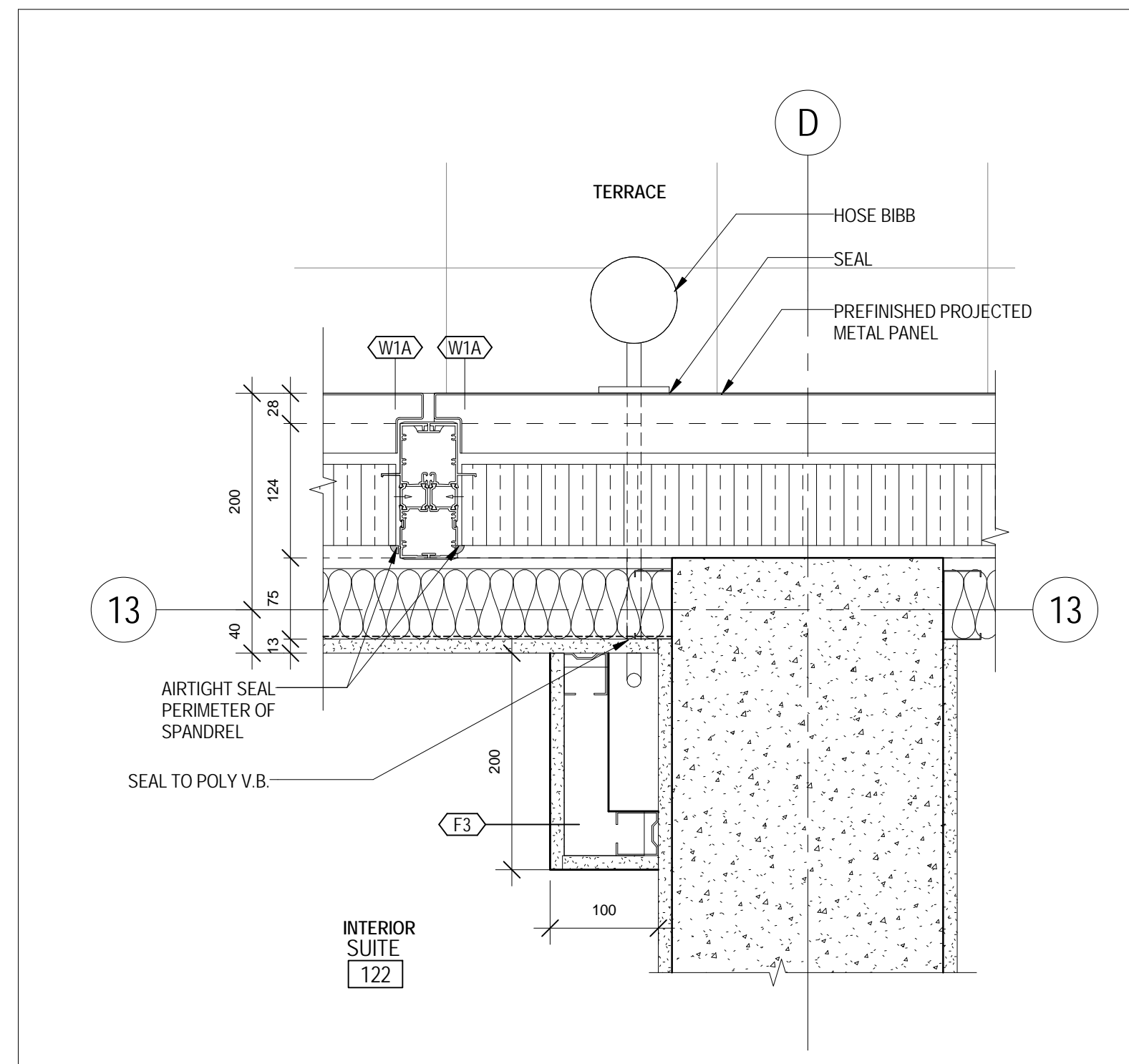

9 HOSE BIBB CONDITION 1
1/A 203 1:5

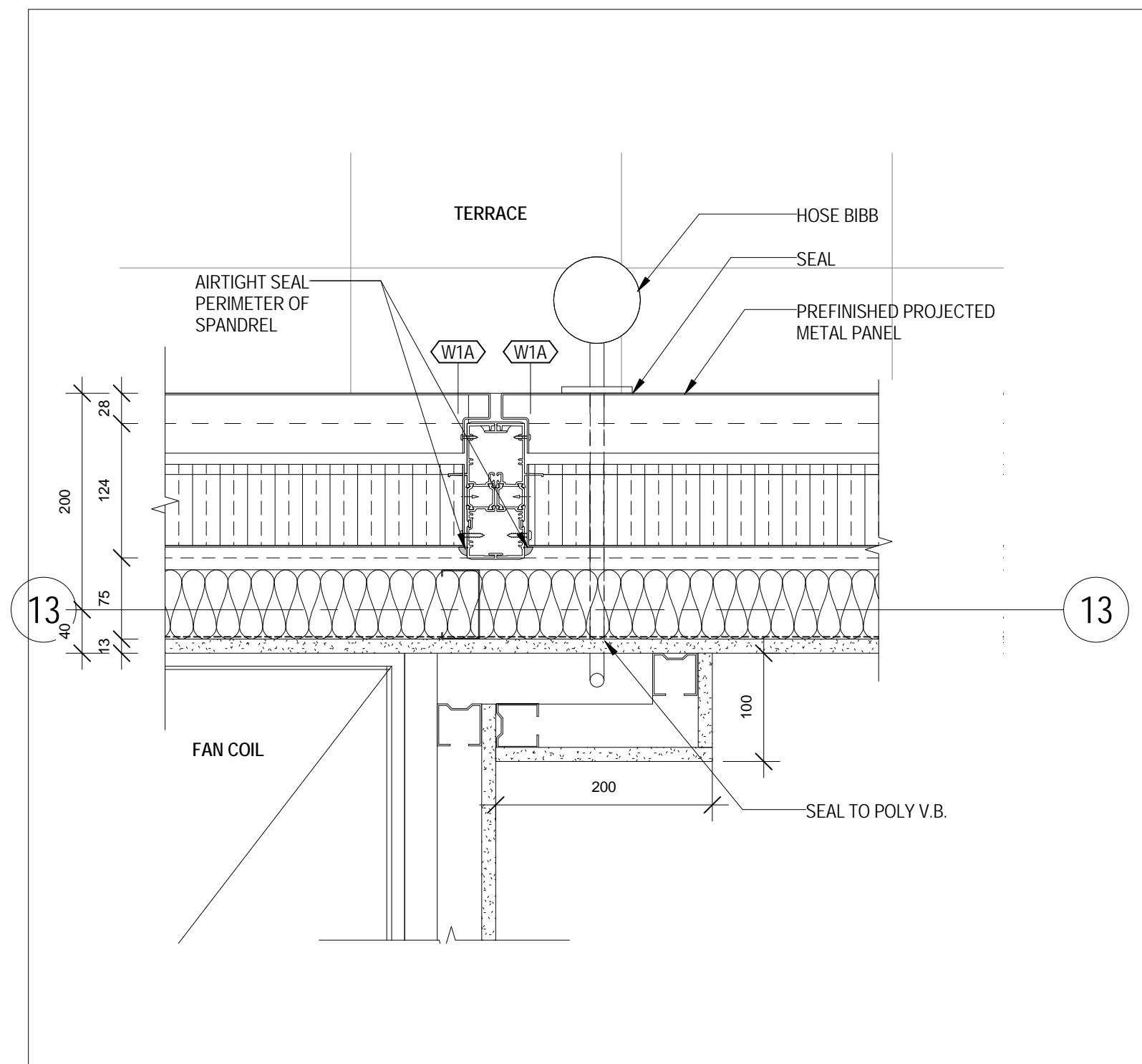

6 HOSE BIBB CONDITION 2
1/A 203 1:5

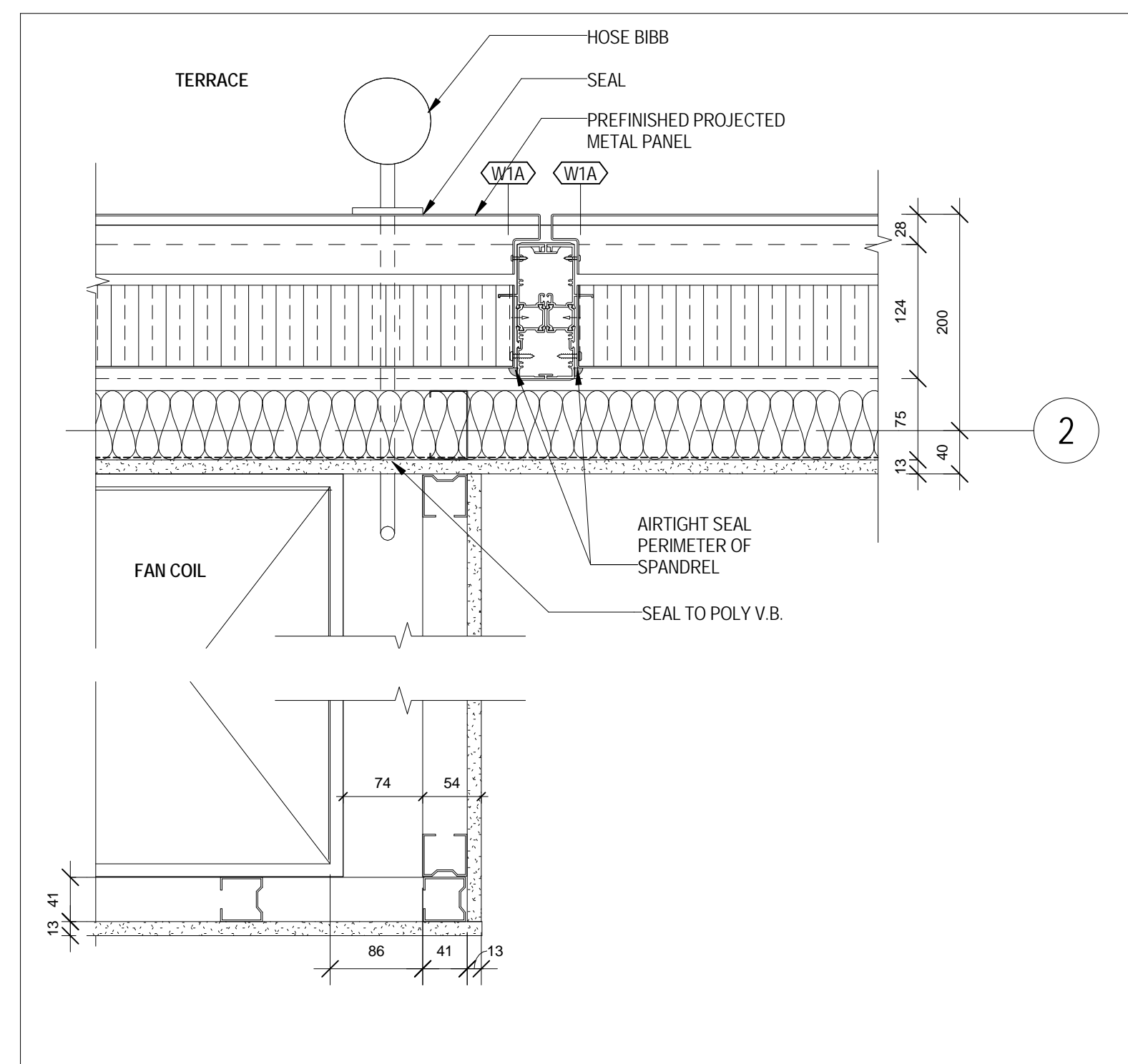

8 HOSE BIBB CONDITION 3
1/A 205 1:5

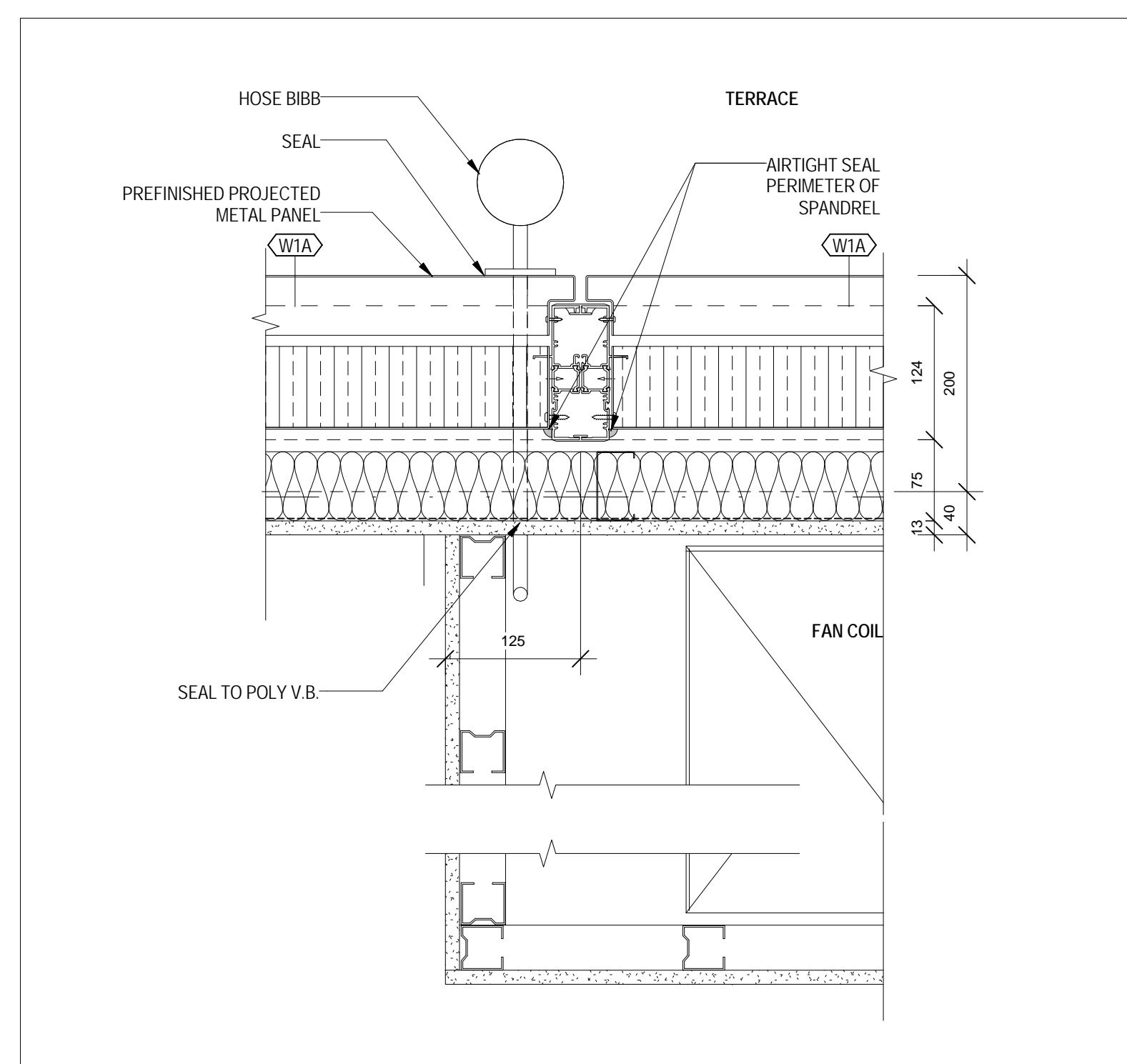

7 HOSE BIBB CONDITION 4
1/A 213 1:5

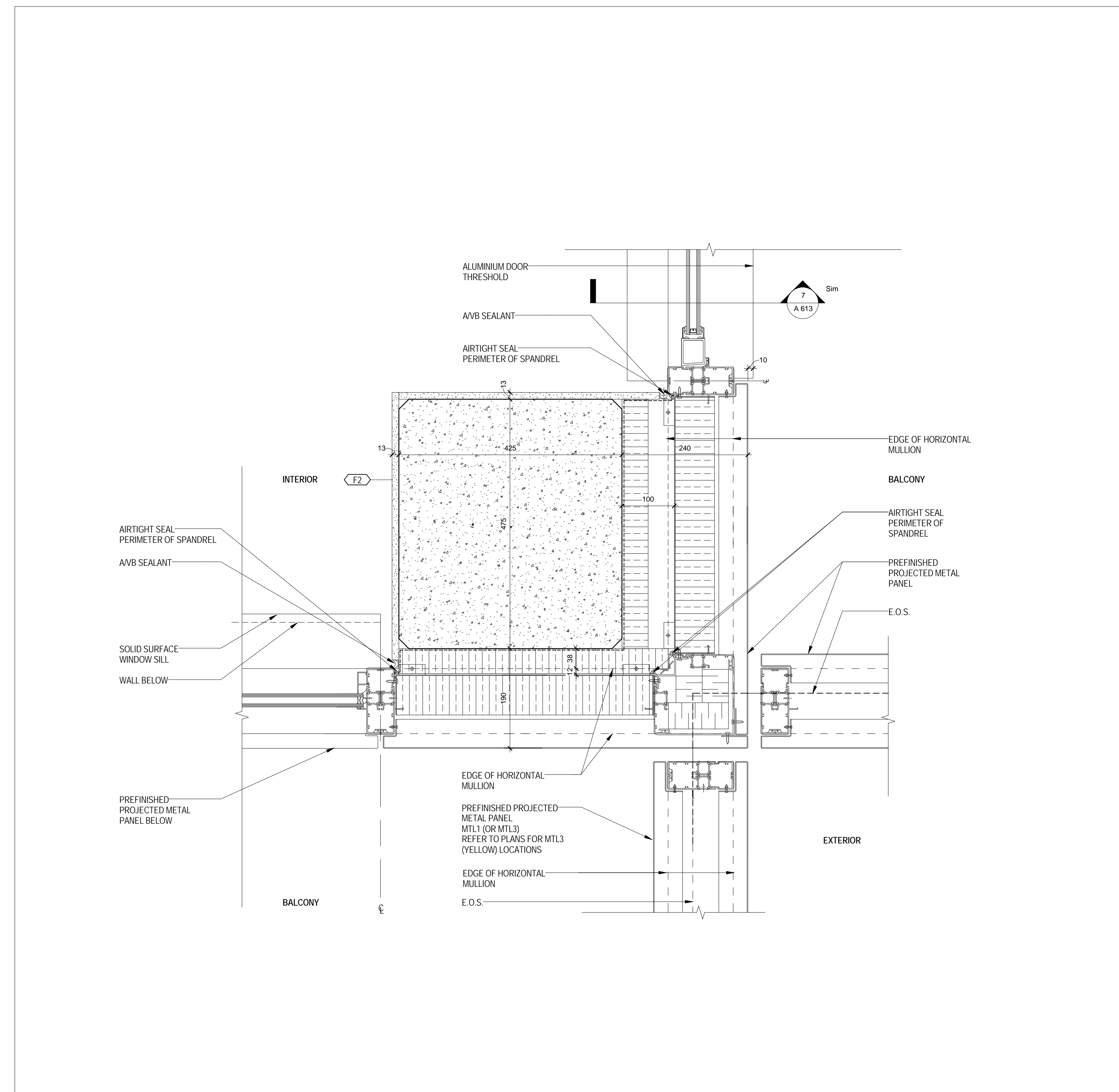

4 EXTERIOR WALL CORNER - AT CORNER COLUMN AND DOUBLE BALCONY
1:5

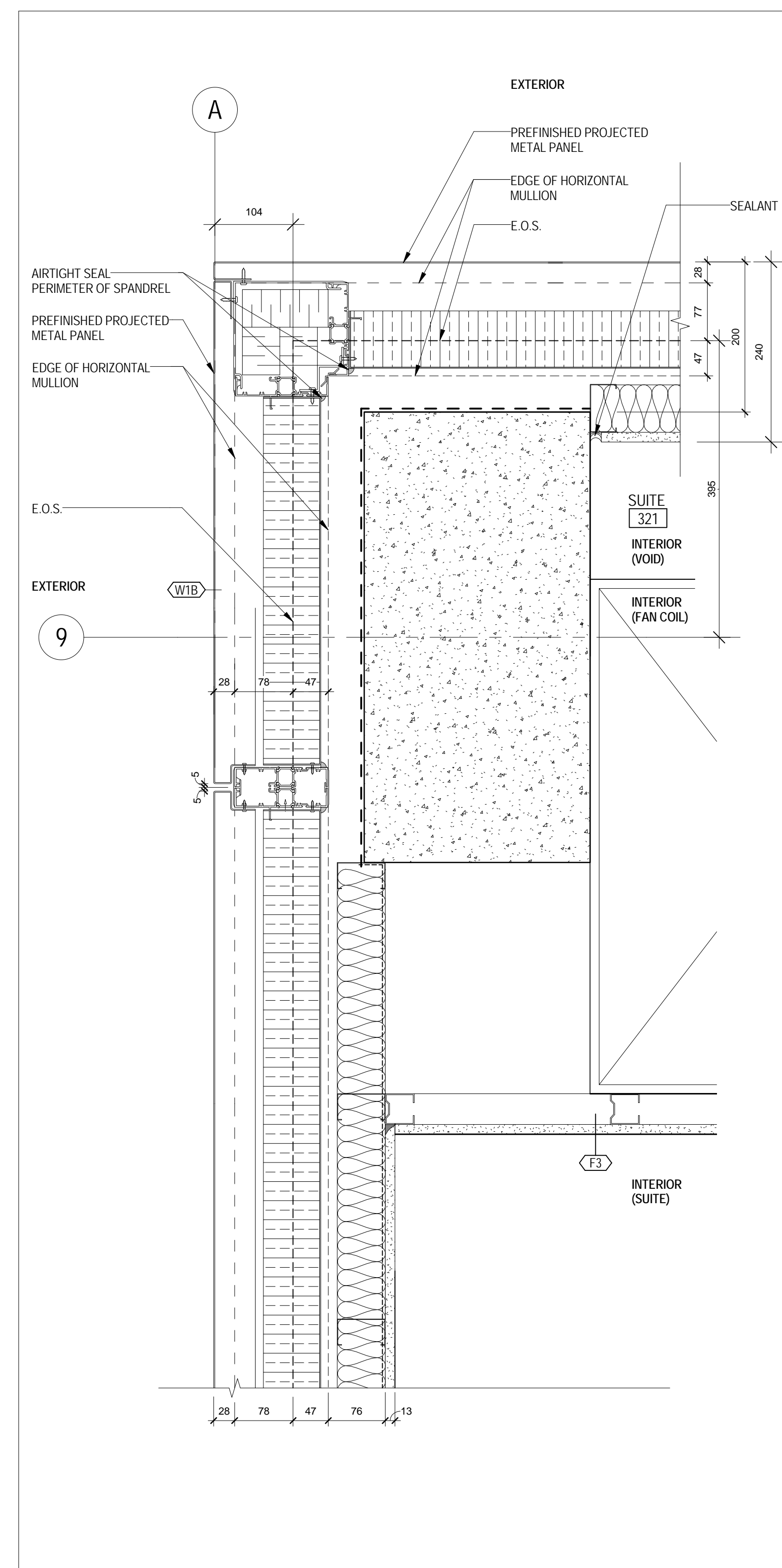

5 EXTERIOR WALL CORNER
1/A 207 1:5

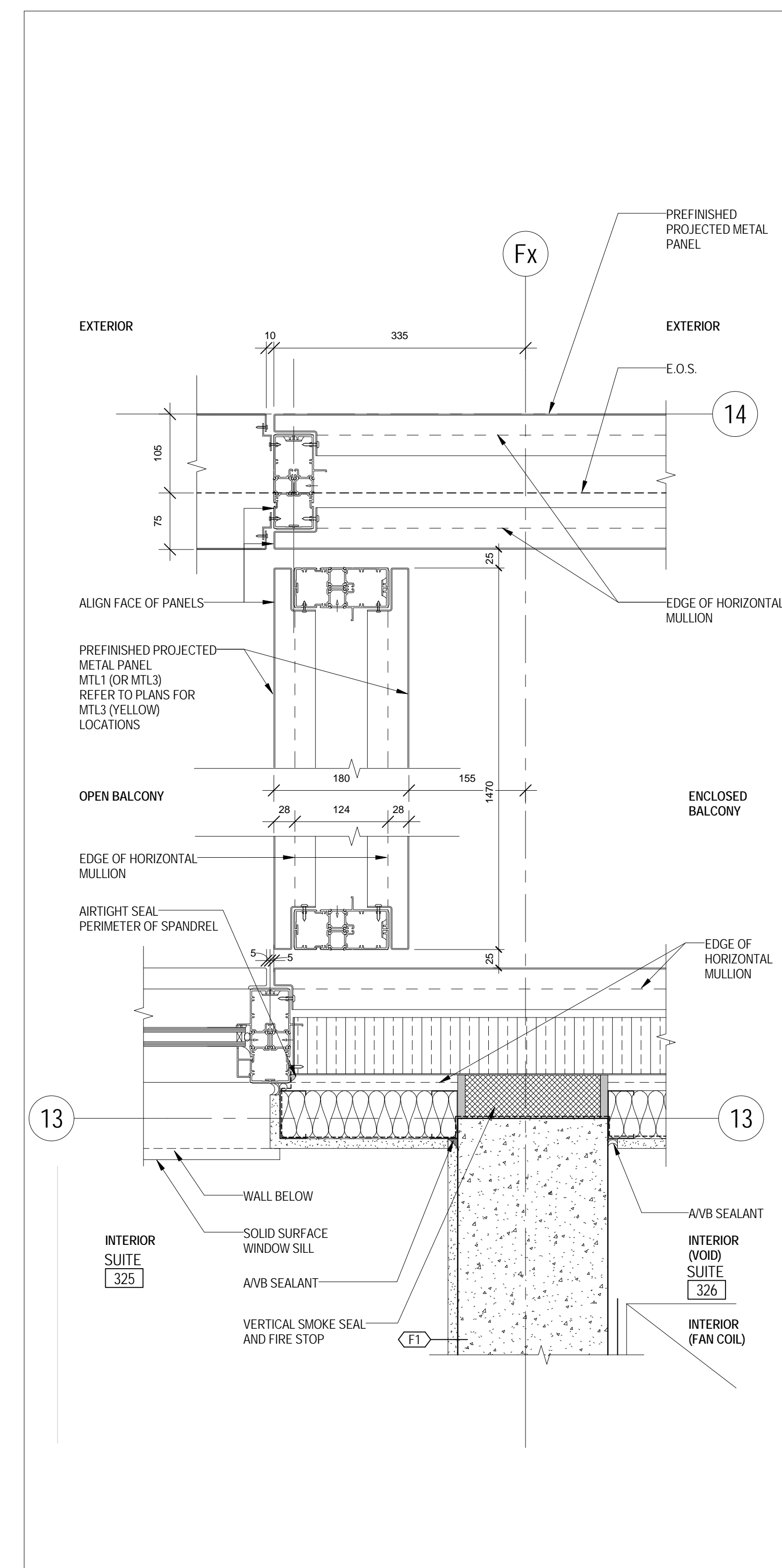

3 ENCLOSED BALCONY TO OPEN BALCONY CONNECTION
1/A 201 1:5

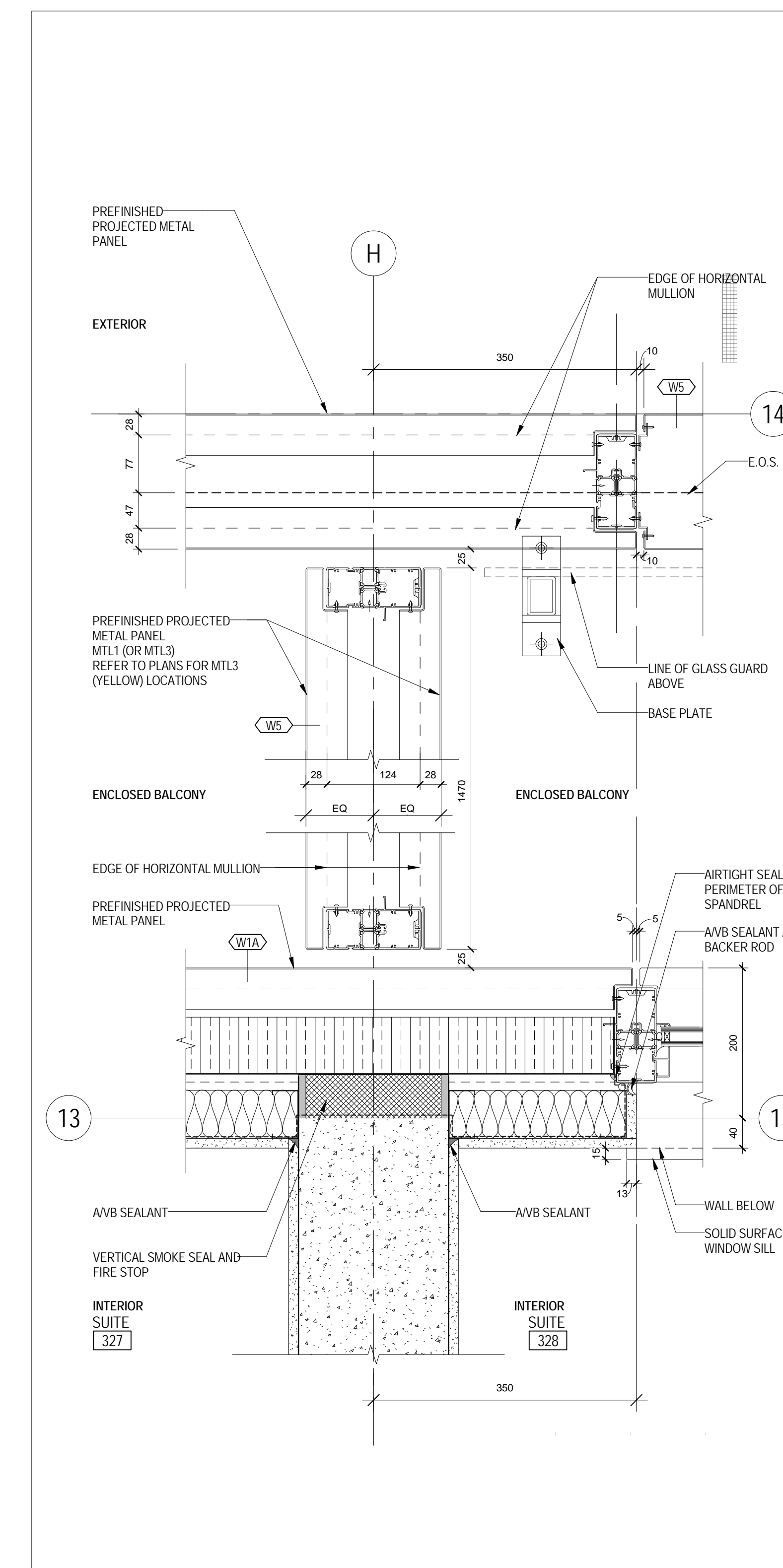

2 ENCLOSED BALCONY TO ENCLOSED BALCONY CONNECTION
1/A 208 1:5

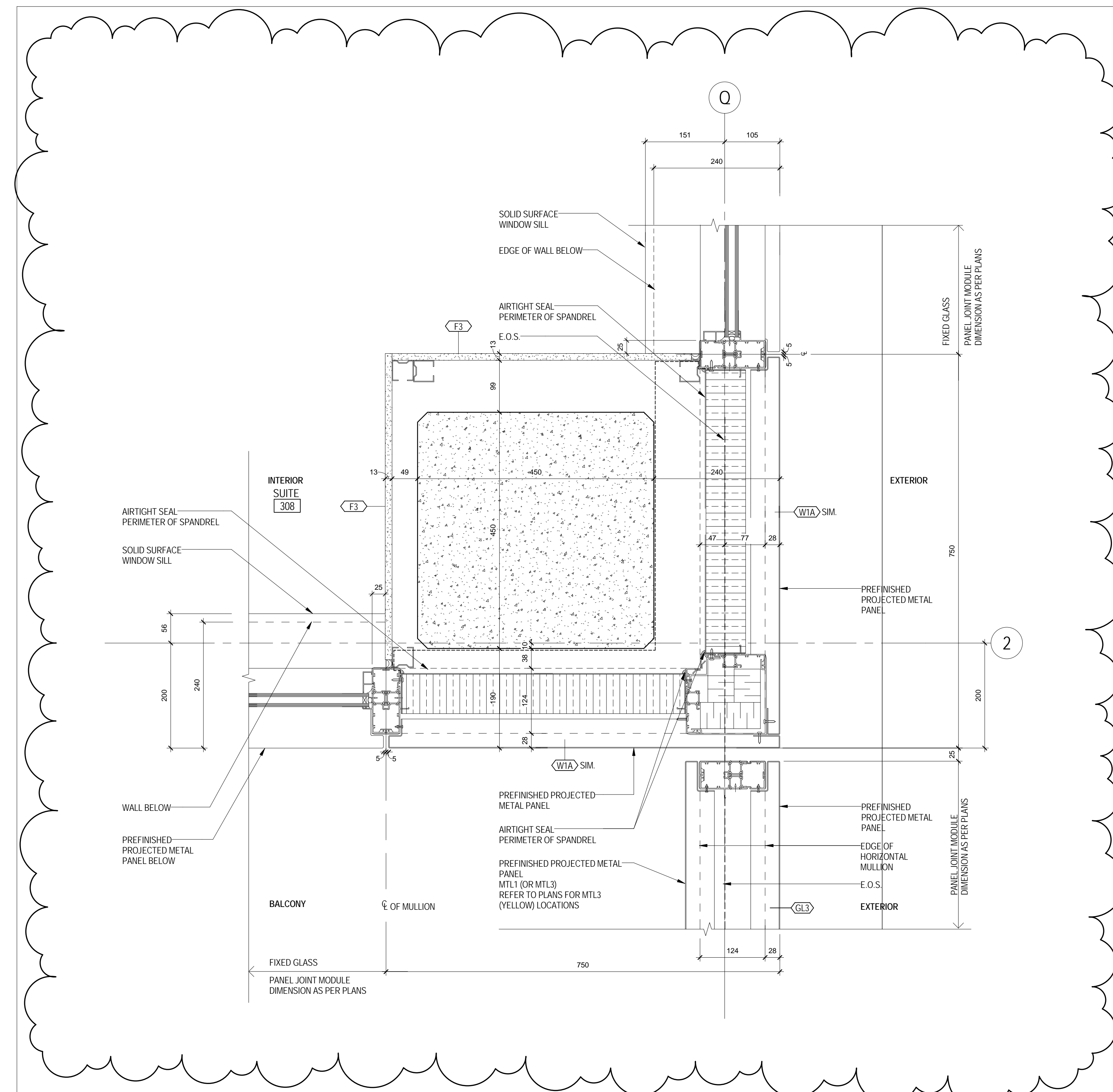

1 EXTERIOR WALL CORNER - AT COLUMN AND BALCONY
1/A 209 1:5

THIS DRAWING IS THE PROPERTY OF SQ SPADINA QUEEN TRIDEL. IT IS TO BE USED FOR THE PROJECT AND NOT TO BE REPRODUCED OR TRANSMITTED IN ANY FORM OR BY ANY MEANS, ELECTRONIC OR MECHANICAL, INCLUDING PHOTOCOPYING, RECORDING, OR BY ANY INFORMATION STORAGE AND RETRIEVAL SYSTEM. WITHOUT THE WRITTEN PERMISSION OF SQ SPADINA QUEEN TRIDEL.



METRIC SCALE DRAWING
FIRST FLOOR ELEV. +93.60m

No.	ISSUED/REVISION FOR	DATE
1	Issued for Permit	2014-09-22
2	Issued for Tender	2014-09-26
3	Issued for Tender	2014-09-29
4	Issued for Tender	2015-05-29
5	Issued for Grand Tender	2015-06-19
6	Issued for AS21	2015-10-04

SQ ALEXANDRA PARK - BLOCK 11
38 CAMERON ST., TORONTO, ONTARIO M5T 2H2

project no. 12-115
scale: 1:5
drawn by: Aur
reviewed by: Chack
date: 2014-09-22

Teepie Architects

PLAN DETAILS - TYPICAL