

GENERAL AREA CIRCUITING - TABLE #1

LIGHTING FIXTURE LOCATION	CGT.#
P2 TO P1 - EXIT SIGNS	E-1
G/F TO MPH - EXIT SIGNS	E-3
MPH - EXIT SIGNS	ER-1
STAIR 'A' (F2 TO G/F)	E-5
STAIR 'B' (F2 TO G/F)	E-7
STAIR 'J' (G/F TO 4/F)	E-9
STAIR 'U' (G/F TO 3/F)	E-11
STAIR 'G' (G/F TO 14/F)	E-13
STAIR 'F' (G/F TO 14/F)	E-15
STAIR 'K' (14/F TO MPH) 4 MPH (G/F)	ER-3ER-5R-11R-19
(G/F)	E-2E-4E-6E-16E-18E-10E-12E-14E-16
(G/F)	B1-2B1-4B1-6B1-8B1-10B1-12B1-14B1-16B1-18B1-20B1-22B1-24B1-26B1-28B1-30
CORRIDOR (2/F 4 3/F)	E-24
CORRIDOR (4/F 4 15/F)	E-26
CORRIDOR (6/F 4 17/F)	E-28
CORRIDOR (8/F TO 11/F)	E-30
CORRIDOR (12/F TO 14/F)	E-32
CORRIDOR 4 LOCKER (2/F)	B-46
CORRIDOR (3/F)	B-48
CORRIDOR (4/F)	B-50
CORRIDOR (5/F 4 6/F)	B-52
CORRIDOR (7/F 4 8/F)	B-54
CORRIDOR (9/F TO 11/F)	B-56
CORRIDOR (12/F TO 14/F)	B-58
ELEVATOR CAB	ER-6, ER-8ER-10
EXTERIOR SITE	E1-E11-3E1-5E1-7E1-4E1-6

RECEPTACLE LOCATION CGT.#

ELEC. S. CLOSET (G/F TO 3/F)	B-2
ELEC. N. CLOSET (2/F TO 3/F)	B-4
ELEC. N. CLOSET (10/F TO 14/F)	B-6
ELEC. N. CLOSET (22/F TO 32/F)	B-8
ELEV. LOBBY (F2 TO 8/F)	B-10
CORRIDOR (2/F TO 8/F)	B-12B-14B-16B-18B-20B-22B-24
CORRIDOR (2/F TO 5/F)	B-26B-28
ELEV. LOBBY (9 TO 14/F)	B-30
CORRIDOR (9/F TO 14/F)	B-32B-34B-36B-38
STAIR A (G/F) 4 (J/9/F/6/F/3/F)	B-40
STAIR F (14/F/11/F/8/F/5/F)	B-42
STAIR H (14/F/11/F/8/F/5/F)	B-44
STAIR 'K' 4 MPH	R-2

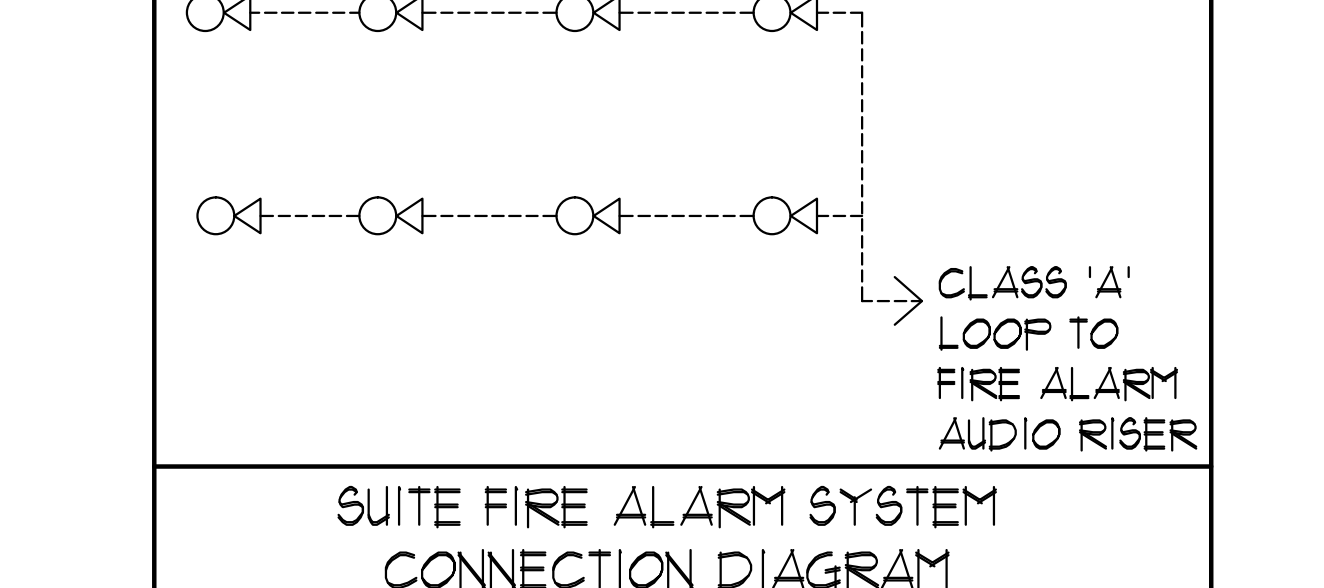

SUITE FIRE ALARM SYSTEM CONNECTION DIAGRAM

MOUNTING HEIGHT SCHEDULE (TO TOP OF BOX)

OUTLET	SUITES	PUBLIC AREA
RECEPTACLE	400 MM AFF.	400 MM AFF.
TV OUTLET	400 MM AFF.	400 MM AFF.
TELEPHONE OUTLET	400 MM AFF.	400 MM AFF.
MULTI-FORT OUTLET	400 MM AFF.	400 MM AFF.
SWITCH	1200 MM AFF.	1200 MM AFF.
SECURITY PANEL	1200 MM AFF.	1200 MM AFF.
SILENCE SWITCHES	1200 MM AFF.	1200 MM AFF.
THERMOSTAT	1200 MM AFF.	1200 MM AFF.
INTERCOM	1200 MM AFF.	1200 MM AFF.
V.C. HANDSET	1200 MM AFF.	1200 MM AFF.
FULL STATION	1200 MM AFF.	1200 MM AFF.

- GENERAL NOTES - RESIDENTIAL:**
- ELECTRICAL DRAWINGS SHALL BE READ IN CONJUNCTION WITH MECHANICAL, STRUCTURAL, ARCHITECTURAL AND LANDSCAPE DRAWINGS.
 - CONTRACTOR SHALL RUN CABLES WITHIN CEILING SLAB OR ENCLOSURES TO RETAIN 2 HOUR FIRE PROTECTION RATING FOR ALL LOADS THAT CONNECT TO EMERGENCY POWER.
 - FIRE ALARM RISERS SHALL BE RUN IN 2 HOUR FIRE RATED ELECTRICAL CLOSET. REFER TO DUG. E-32 FOR RISER DIAGRAM AND DETAILS.
 - STAIRWAY WALL MOUNTED EMERGENCY LIGHT FIXTURES SHALL BE MOUNTED @ 1" AFF. MIN.
 - FOR STORAGE ROOM VENTILATION SYSTEM, DIV. 16 TO PROVIDE CONDUIT, WIRING AND SWITCH (S) TO START/STOP FAN AND DAMPER. FAN AND 110V ACTUATOR TO BE SUPPLIED AND INSTALLED BY DIV. 15.
 - FOR UTILITY ROOM VENTILATION SYSTEM, DIV. 15 WILL PROVIDE LINE VOLTAGE THERMOSTAT (T) TO DIV. 16. DIV. 16 TO PROVIDE CONDUIT AND WIRING TO START/STOP FAN AND DAMPER VIA THERMOSTAT. FAN AND 110V ACTUATOR TO BE SUPPLIED AND INSTALLED BY DIV. 15.
 - FOR UNIT HEATER, DIV. 15 TO PROVIDE LINE VOLTAGE THERMOSTAT (T), DIV. 16 TO PROVIDE CONDUIT AND WIRING TO START/STOP UNIT HEATER.
 - REFER TO SPRINKLER DRAWINGS FOR FIRE PROTECTION DEVICE TO BE CONNECTED TO THE FIRE ALARM SYSTEM. THE DEVICE AND EQUIPMENT SHALL FORM AN INTEGRAL PART OF THE ELECTRICAL CONTRACT.
 - DIV. 16 SHALL SUPPLY AND INSTALL CONDUITS, WIRES AND INTERLOCK FANS TO MOTORIZED DAMPERS AND TO THE THERMOSTAT.
 - DIV. 16 SHALL SUPPLY AND INSTALL CONDUITS, WIRES AND INTERLOCK FANS TO MOTORIZED DAMPERS AND TO THE THERMOSTAT.
 - REFER TO SUITE PANEL SCHEDULES FOR INSUITE CIRCUIT ARRANGEMENT.
 - ALL DWELLING UNIT RECEPTACLES EXCEPT IN KITCHEN SHALL BE TAMPER PROOF.
 - PROVIDE GROUND FAULT PROTECTION FOR SUITE KITCHEN, AMENITY KITCHEN AND WASHROOM RECEPTACLES WITHIN 1500mm OF SINK.
 - PROVIDE TELECOMMUNICATION BOX C/W BUILT-IN RECEPTACLE FOR TELECOMMUNICATION. TELECOMMUNICATION BOX SHALL BE COMPLIANT WITH THE TELECOM SERVICE PROVIDER SPECIFICATION. REFER TO DETAIL #3 ON DUG. E-35 FOR TELECOM JUNCTION BOX INSTALLATION.
 - DRYER SENSOR TO START DRYER VENTILATION FAN AUTOMATICALLY WHEN DRYER IS RUNNING.
 - ALL SMOKE ALARMS WITHIN THE SUITE SHALL BE HARDWIRED TOGETHER AND TO A 15A, 1P CIRCUIT BREAKER AHEAD OF OTHER LOADS.
 - ALL OUTDOOR RECEPTACLES SHALL BE WEATHERPROOF (LEGRADE CAT# 2322TRUR-GRY FOR NON-GFCI AND CAT# 1955TRUR-GRY FOR GFCI) AND SHALL BE EQUIPPED WITH A WHILE IN USE CAST ALUMINUM COVERPLATE (LEGRADE CAT# WUICAST) COVERPLATE.

- KEY NOTES - RESIDENTIAL - COMMON AREA:**
- FOR CIRCUITING, REFER TO TABLE #1.
 - PROVIDE ALARM SPEAKER, SMOKE DETECTOR AND RECEPTACLE AT EVERY THIRD FLOOR STAIR WELL, STARTING FROM TOP FLOOR, AS PER TO DUG. E-32 FOR FIRE ALARM RISER DIAGRAM.
 - PROVIDE TELECOMMUNICATION BACKBOARD C/W 110V, 1P 15A RECEPTACLE AS PER COMMUNICATION RISER DIAGRAM ON DUG. E-31.
 - CONTRACTOR SHALL REFER TO ELECTRICAL SINGLE LINE DIAGRAM ON DUG. E-30 AND SDP RISER ON DUG. E-31 FOR SDP LOCATIONS AND DISTRIBUTION.
 - PROVIDE CONDUIT AS PER RISER DETAIL #3 ON DUG. E-35 FOR RISER CONTROL SYSTEM.
 - REFER TO SUPERVISED VALVE AND FLOW SWITCH SCHEDULE ON DUG. E-33 FOR DETAILS ON TYPICAL FLOORS.
 - EMERGENCY LIGHT FIXTURES IN LOCKERS, STORAGE, GARBAGE, UTILITY AND SERVICE ROOMS SHALL BE CONNECTED TO BOTH NORMAL AND EMERGENCY POWER AS PER DETAIL #21 OF DUG. E-35.

ELECTRICAL LEGEND

LIGHTING

- FLUORESCENT LIGHT FIXTURE, TYPE AS INDICATED
- LIGHT CONNECTED TO EMERGENCY POWER
- CEILING MOUNTED WALL MOUNTED LIGHT FIXTURE, INCREASED LETTER DENOTES TYPE
- POLE MOUNTED LIGHT FIXTURE, INCREASED LETTER DENOTES TYPE
- CARRIED CEILING LIGHT OUTLET
- TRACK LIGHT
- STRIP LIGHT
- UNDER CABINET FLUORESCENT LIGHT FIXTURE
- CEILING MOUNTED WALL MOUNTED EXIT SIGN
- RECURRING EMERGENCY LIGHT REFLECTOR HEAD
- EMERGENCY BATTERY PACK
- OCCUPANCY SENSOR POWER PACKS
- SINGLE/TWO/THREE POLE SINGLE/TWO/THREE THROW TOGGLE SWITCH RESPECTIVELY
- 1/4" x 1/4" x 1/4" DENOTES 3-WAY/4-WAY/FLOAT LIGHT, SWITCH SWITCHED LIGHT RESPECTIVELY
- MASTER LIGHTING SHUT-OFF SWITCH
- SENSOR WALL SWITCH FIR. SELF POWERED
- OCCUPANCY SENSOR CEILING MOUNTED

POWER

- REGULAR DUPLEX RECEPTACLE
- DUPLEX RECEPTACLE GROUND FAULT INTERRUPT
- 3-WAY/4-WAY DUPLEX RECEPTACLE
- ANGLE RECEPTACLE TYPE AND CONFIGURATION AS SPECIFIED FOR DRIVER
- CONNECTION FOR OVEN/COOKTOP
- SMOKE COUPLER DEVICE
- FLOOR MOUNTED DEVICES
- DISCONNECT SWITCH NON-FUSED
- DISCONNECT SWITCH FUSED
- OPERATION STARTER
- FRACTIONAL MOTOR/FAN DIRECT CONNECTION
- DIRECT CONNECTION SINGLE PHASE
- DIRECT CONNECTION THREE PHASE
- THERMOSTAT
- DRYER SENSOR
- HEAT TRACE
- ELECTRIC HEATER
- ELECTRICAL PANEL / SECURITY PANEL

TELECOMMUNICATION

- TV/CABLE OUTLET
- TELEPHONE OUTLET
- TELEPHONE/CABLE (MULTI-PORT) OUTLET
- DATA OUTLET
- DATA/TELEPHONE OUTLET
- N SUITE TELECOM BOX C/W RECEPTACLE
- WIFI LOCATION
- VIDEO INTERCOM
- RADIO RECEIVER

SECURITY

- INTERCOM / ENTERPHONE
- INTERCOM WITH CAMERA
- PANIC BUTTON / PANIC INTERCOM STATION
- CARD READER
- AUTOMATIC RELEASE CARD ACCESS/RADIO RECEIVER
- ELECTRIC STRIKE
- MAGLOCK
- DOOR CONTACT / WINDOW CONTACT
- GLASS BREAK DETECTOR
- AUTOMATIC DOOR OPERATOR
- MOTION DETECTOR
- PUSH BUTTON
- SECURITY CAMERA

LIFE SAFETY

- FIRE ALARM SMOKE DETECTOR
- SMOKE ALARM
- FIRE ALARM DUST TYPE SMOKE DETECTOR
- FIRE ALARM HEAT DETECTOR
- FIXED TEMP. 68 °C DEGREE HEAT DETECTOR
- SMOKE PROOF HEAT DETECTOR
- CO ALARM
- COMBINATION SMOKE 4 CO ALARM
- CO SENSOR / NO SENSOR
- FIRE ALARM MANUAL PULL STATION
- FIREFIGHTER'S HANDSET
- FIRE ALARM SPEAKER/STROBE WALL MTD.
- FIRE ALARM SPEAKER WALL MTD.
- FIRE ALARM SPEAKER/STROBE CEILING MTD.
- FIRE ALARM SPEAKER CEILING MTD.
- FIRE ALARM ANNUNCIATOR PANEL
- FIRE ALARM CONTROL PANEL

REVISIONS

NO.	DATE	DESCRIPTION
02/26/13	1	BASED FOR E1-E4
02/26/13	2	BASED FOR E5-E10
02/26/13	3	BASED FOR E11-E14
02/26/13	4	BASED FOR E15-E18
02/26/13	5	BASED FOR E19-E22
02/26/13	6	RE-BASED FOR TENDER
02/26/13	7	RE-BASED FOR RISER
02/26/13	8	RE-BASED FOR PERMIT
02/26/13	9	RE-BASED FOR PERMIT
02/26/13	10	RE-BASED FOR PERMIT
02/26/13	11	RE-BASED FOR PERMIT
02/26/13	12	RE-BASED FOR PERMIT
02/26/13	13	RE-BASED FOR PERMIT
02/26/13	14	RE-BASED FOR PERMIT
02/26/13	15	RE-BASED FOR PERMIT
02/26/13	16	RE-BASED FOR PERMIT
02/26/13	17	RE-BASED FOR PERMIT
02/26/13	18	RE-BASED FOR PERMIT
02/26/13	19	RE-BASED FOR PERMIT
02/26/13	20	RE-BASED FOR PERMIT
02/26/13	21	RE-BASED FOR PERMIT
02/26/13	22	RE-BASED FOR PERMIT
02/26/13	23	RE-BASED FOR PERMIT
02/26/13	24	RE-BASED FOR PERMIT
02/26/13	25	RE-BASED FOR PERMIT
02/26/13	26	RE-BASED FOR PERMIT
02/26/13	27	RE-BASED FOR PERMIT
02/26/13	28	RE-BASED FOR PERMIT
02/26/13	29	RE-BASED FOR PERMIT
02/26/13	30	RE-BASED FOR PERMIT
02/26/13	31	RE-BASED FOR PERMIT
02/26/13	32	RE-BASED FOR PERMIT
02/26/13	33	RE-BASED FOR PERMIT
02/26/13	34	RE-BASED FOR PERMIT
02/26/13	35	RE-BASED FOR PERMIT
02/26/13	36	RE-BASED FOR PERMIT
02/26/13	37	RE-BASED FOR PERMIT
02/26/13	38	RE-BASED FOR PERMIT
02/26/13	39	RE-BASED FOR PERMIT
02/26/13	40	RE-BASED FOR PERMIT
02/26/13	41	RE-BASED FOR PERMIT
02/26/13	42	RE-BASED FOR PERMIT
02/26/13	43	RE-BASED FOR PERMIT
02/26/13	44	RE-BASED FOR PERMIT
02/26/13	45	RE-BASED FOR PERMIT
02/26/13	46	RE-BASED FOR PERMIT
02/26/13	47	RE-BASED FOR PERMIT
02/26/13	48	RE-BASED FOR PERMIT
02/26/13	49	RE-BASED FOR PERMIT
02/26/13	50	RE-BASED FOR PERMIT
02/26/13	51	RE-BASED FOR PERMIT
02/26/13	52	RE-BASED FOR PERMIT
02/26/13	53	RE-BASED FOR PERMIT
02/26/13	54	RE-BASED FOR PERMIT
02/26/13	55	RE-BASED FOR PERMIT
02/26/13	56	RE-BASED FOR PERMIT
02/26/13	57	RE-BASED FOR PERMIT
02/26/13	58	RE-BASED FOR PERMIT
02/26/13	59	RE-BASED FOR PERMIT
02/26/13	60	RE-BASED FOR PERMIT
02/26/13	61	RE-BASED FOR PERMIT
02/26/13	62	RE-BASED FOR PERMIT
02/26/13	63	RE-BASED FOR PERMIT
02/26/13	64	RE-BASED FOR PERMIT
02/26/13	65	RE-BASED FOR PERMIT
02/26/13	66	RE-BASED FOR PERMIT
02/26/13	67	RE-BASED FOR PERMIT
02/26/13	68	RE-BASED FOR PERMIT
02/26/13	69	RE-BASED FOR PERMIT
02/26/13	70	RE-BASED FOR PERMIT
02/26/13	71	RE-BASED FOR PERMIT
02/26/13	72	RE-BASED FOR PERMIT
02/26/13	73	RE-BASED FOR PERMIT
02/26/13	74	RE-BASED FOR PERMIT
02/26/13	75	RE-BASED FOR PERMIT
02/26/13	76	RE-BASED FOR PERMIT
02/26/13	77	RE-BASED FOR PERMIT
02/26/13	78	RE-BASED FOR PERMIT
02/26/13	79	RE-BASED FOR PERMIT
02/26/13	80	RE-BASED FOR PERMIT
02/26/13	81	RE-BASED FOR PERMIT
02/26/13	82	RE-BASED FOR PERMIT
02/26/13	83	RE-BASED FOR PERMIT
02/26/13	84	RE-BASED FOR PERMIT
02/26/13	85	RE-BASED FOR PERMIT
02/26/13	86	RE-BASED FOR PERMIT
02/26/13	87	RE-BASED FOR PERMIT
02/26/13	88	RE-BASED FOR PERMIT
02/26/13	89	RE-BASED FOR PERMIT
02/26/13	90	RE-BASED FOR PERMIT
02/26/13	91	RE-BASED FOR PERMIT
02/26/13	92	RE-BASED FOR PERMIT
02/26/13	93	RE-BASED FOR PERMIT
02/26/13	94	RE-BASED FOR PERMIT
02/26/13	95	RE-BASED FOR PERMIT
02/26/13	96	RE-BASED FOR PERMIT
02/26/13	97	RE-BASED FOR PERMIT
02/26/13	98	RE-BASED FOR PERMIT
02/26/13	99	RE-BASED FOR PERMIT
02/26/13	100	RE-BASED FOR PERMIT

NOVA TREND CONSULTING

175 West Beaver Creek Road, Unit 31
Richmond Hill, Ontario L4B 3M1
Tel: 905 882-5445
Fax: 905 882-5441
Email: info@novatrendeng.com

REVISIONS

NO.	DATE	DESCRIPTION
1	02/26/13	BASED FOR E1-E4
2	02/26/13	BASED FOR E5-E10
3	02/26/13	BASED FOR E11-E14
4	02/26/13	BASED FOR E15-E18
5	02/26/13	BASED FOR E19-E22
6	02/26/13	RE-BASED FOR TENDER
7	02/26/13	RE-BASED FOR RISER
8	02/26/13	RE-BASED FOR PERMIT
9	02/26/13	RE-BASED FOR PERMIT
10	02/26/13	RE-BASED FOR PERMIT
11	02/26/13	RE-BASED FOR PERMIT
12	02/26/13	RE-BASED FOR PERMIT
13	02/26/13	RE-BASED FOR PERMIT
14	02/26/13	RE-BASED FOR PERMIT
15	02/26/13	RE-BASED FOR PERMIT
16	02/26/13	RE-BASED FOR PERMIT
17	02/26/13	RE-BASED FOR PERMIT
18	02/26/13	RE-BASED FOR PERMIT
19	02/26/13	RE-BASED FOR PERMIT
20	02/26/13	RE-BASED FOR PERMIT
21	02/26/13	RE-BASED FOR PERMIT
22	02/26/13	RE-BASED FOR PERMIT
23	02/26/13	RE-BASED FOR PERMIT
24	02/26/13	RE-BASED FOR PERMIT
25	02/26/13	RE-BASED FOR PERMIT
26	02/26/13	RE-BASED FOR PERMIT
27	02/26/13	RE-BASED FOR PERMIT
28	02/26/13	RE-BASED FOR PERMIT
29	02/26/13	RE-BASED FOR PERMIT
30	02/26/13	RE-BASED FOR PERMIT
31	02/26/13	RE-BASED FOR PERMIT
32	02/26/13	RE-BASED FOR PERMIT
33	02/26/13	RE-BASED FOR PERMIT
34	02/26/13	RE-BASED FOR PERMIT
35	02/26/13	RE-BASED FOR PERMIT
36	02/26/13	RE-BASED FOR PERMIT
37	02/26/13	RE-BASED FOR PERMIT
38	02/26/13	RE-BASED FOR PERMIT
39	02/26/13	RE-BASED FOR PERMIT
40	02/26/13	RE-BASED FOR PERMIT
41	02/26/13	RE-BASED FOR PERMIT
42	02/26/13	RE-BASED FOR PERMIT
43	02/26/13	RE-BASED FOR PERMIT
44	02/26/13	RE-BASED FOR PERMIT
45	02/26/13	RE-BASED FOR PERMIT
46	02/26/13	RE-BASED FOR PERMIT
47	02/26/13	RE-BASED FOR PERMIT
48	02/26/13	RE-BASED FOR PERMIT
49	02/26/13	RE-BASED FOR PERMIT
50	02/26/13	RE-BASED FOR PERMIT
51	02/26/13	RE-BASED FOR PERMIT
52	02/26/13	RE-BASED FOR PERMIT
53	02/26/13	RE-BASED FOR PERMIT
54	02/26/13	RE-BASED FOR PERMIT
55	02/26/13	RE-BASED FOR PERMIT
56	02/26/13	RE-BASED FOR PERMIT
57	02/26/13	RE-BASED FOR PERMIT
58	02/26/13	RE-BASED FOR PERMIT
59	02/26/13	RE-BASED FOR PERMIT
60	02/26/13	RE-BASED FOR PERMIT
61	02/26/13	RE-BASED FOR PERMIT
62	02/26/13	RE-BASED FOR PERMIT
63	02/26/13	RE-BASED FOR PERMIT
64	02/26/13	RE-BASED FOR PERMIT
65	02/26/13	RE-BASED FOR PERMIT
66	02/26/13	RE-BASED FOR PERMIT
67	02/26/13	RE-BASED FOR PERMIT
68	02/26/13	RE-BASED FOR PERMIT
69	02/26/13	RE-BASED FOR PERMIT
70	02/26/13	RE-BASED FOR PERMIT
71	02/26/13	RE-BASED FOR PERMIT
72	02/26/13	RE-BASED FOR PERMIT
73	02/26/13	RE-BASED FOR PERMIT
74	02/26/13	RE-BASED FOR PERMIT
75	02/26/13	RE-BASED FOR PERMIT
76	02/26/13	RE-BASED FOR PERMIT
77	02/26/13	RE-BASED FOR PERMIT
78	02/26/13	RE-BASED FOR PERMIT
79	02/26/13	RE-BASED FOR PERMIT
80	02/26/13	RE-BASED FOR PERMIT
81	02/26/13	RE-BASED FOR PERMIT
82	02/26/13	RE-BASED FOR PERMIT
83	02/26/13	RE-BASED FOR PERMIT
84	02/26/13	RE-BASED FOR PERMIT
85	02/26/13	RE-BASED FOR PERMIT
86	02/26/13	RE-BASED FOR PERMIT
87	02/26/13	RE-BASED FOR PERMIT
88	02/26/13	RE-BASED FOR PERMIT
89	02/26/13	RE-BASED FOR PERMIT
90	02/26/13	RE-BASED FOR PERMIT
91	02/26/13	RE-BASED FOR PERMIT
92	02/26/13	RE-BASED FOR PERMIT
93	02/26/13	RE-BASED FOR PERMIT
94	02/26/13	RE-BASED FOR PERMIT
95	02/26/13	RE-BASED FOR PERMIT
96	02/26/13	RE-BASED FOR PERMIT
97	02/26/13	RE-BASED FOR PERMIT